



ZHEJIANG HANGCHA IMP. & EXP. CO., LTD.

Factory site: 666 Xiangfu Road,
Hangzhou, Zhejiang, China (311305)

Tel: +86-571-88926735 88926755
Fax: +86-571-88926789 88132890

sales@hcforklift.com
www.hcforklift.com



Follow us on
Facebook



Follow us on
YouTube



Follow us on
WeChat



ISO14001
ISO14001:2015



ISO9001
ISO9001:2015



HANGCHA trucks conform
to the European Safety
Requirements.

2019 VERSION 1/COPYRIGHT 2019/05

HANGCHA GROUP CO., LTD. reserves the right to make any changes without notice concerning colors, equipment, or specifications detailed in this brochure, or to discontinue individual models. The colors of trucks, delivered may differ slightly from those in brochures.



A Series Rider Pallet Truck

with capacities of 2,000 to 3,000kg

The World of Hangcha



A series rider pallet truck

The rider pallet truck is one of the A series pallet truck models. Using the latest AC drive technology, advanced performance, comfort, safe, reliable, low maintenance cost, is the ideal tool for heavy duty and long distance transport operations.

Environment/ Efficiency/ Economy

Li-Ion Technology

- / The power supply is lithium iron phosphate battery. Each cell is provided with the safety protection device, and is safe and reliable.
- / With advanced BMS power supply management system, intercommunication between the lithium battery and vehicle controller can be realized in order to conduct real-time monitoring for the battery status. The service life and safety of the battery can be effectively improved.
- / With high multiplying power discharge technology, the forklift still can output strong power at the end of battery discharge period.
- / Charging and discharge efficiency are higher, the forklift can have longer endurance mileage, the battery is energy-saving and environment-friendly.
- / With fast charging technology, the lithium battery can be fully charged within 2h.
- / The lithium battery pack adopts the fully-enclosed structure, and is safe and reliable.
- / The battery is maintenance-free, does not result in heavy-metal pollution, and is green and environment-friendly.



Appearance

- / A series electric rider pallet truck applied professional industrial design, stream lines, and compact, and fully ergonomic consideration, in line with the latest design trends.
- / Applied steel stamping and injection molding processes for front and back guard, which is robust, durable, and also environmental compliance.

High Performance

- / Electric power steering (EPS) is standard specification, which provides flexible operation.
- / Powered by AC traction motor not only has good acceleration and climbing performance, but also low heat, brushless, maintenance-free.
- / Latest AC control system, precise and smooth.
- / CAN-BUS connection enables all truck data can be read out for inspection, and also improves the data transition more quick and reliable.
- / Regenerative braking for battery recovery during travel speed reduction, anti-slope on gradient.
- / All key parts such as switches, connectors, battery indicator and hour meter all adopt the famous brand.

Reliability

- / Adopted unique floating suspension system ensures good driving wheels' grip and excellent stability.
- / Imported waterproof connectors, all wires and cables are protected, greatly improve the reliability of the electric system.
- / Using non-contact proximity switch, improves safety and reliability.
- / Top quality hydraulic power unit applied to provide low noise, low vibration, smooth lifting and landing reliable operation.
- / Punch formed forks to provide more strength and tip guide to provide higher efficient operation.
- / The power plug is fixed on the truck body to avoid damage from battery installment.

Safety

- / Automatic deceleration during turning.
- / Punch-formed frame provide more safety to the operator.
- / Three braking system of regenerative braking, reverse current braking, parking brake, insures the safe operation.
- / Anti-slope on gradient can keep the safety.
- / The braking button on the tiller head can effectively avoid the harm to the driver.
- / The standard equipped electronic lifting limitation protect the pump motor from damaging dramatically and more energy saving.
- / Displayed turtle speed function applied to move slowly and helps to stack goods in narrow space.

5-pivot with low centre of gravity design and high strength steel frame structure chassis provide larger residual load capability and longer working life.

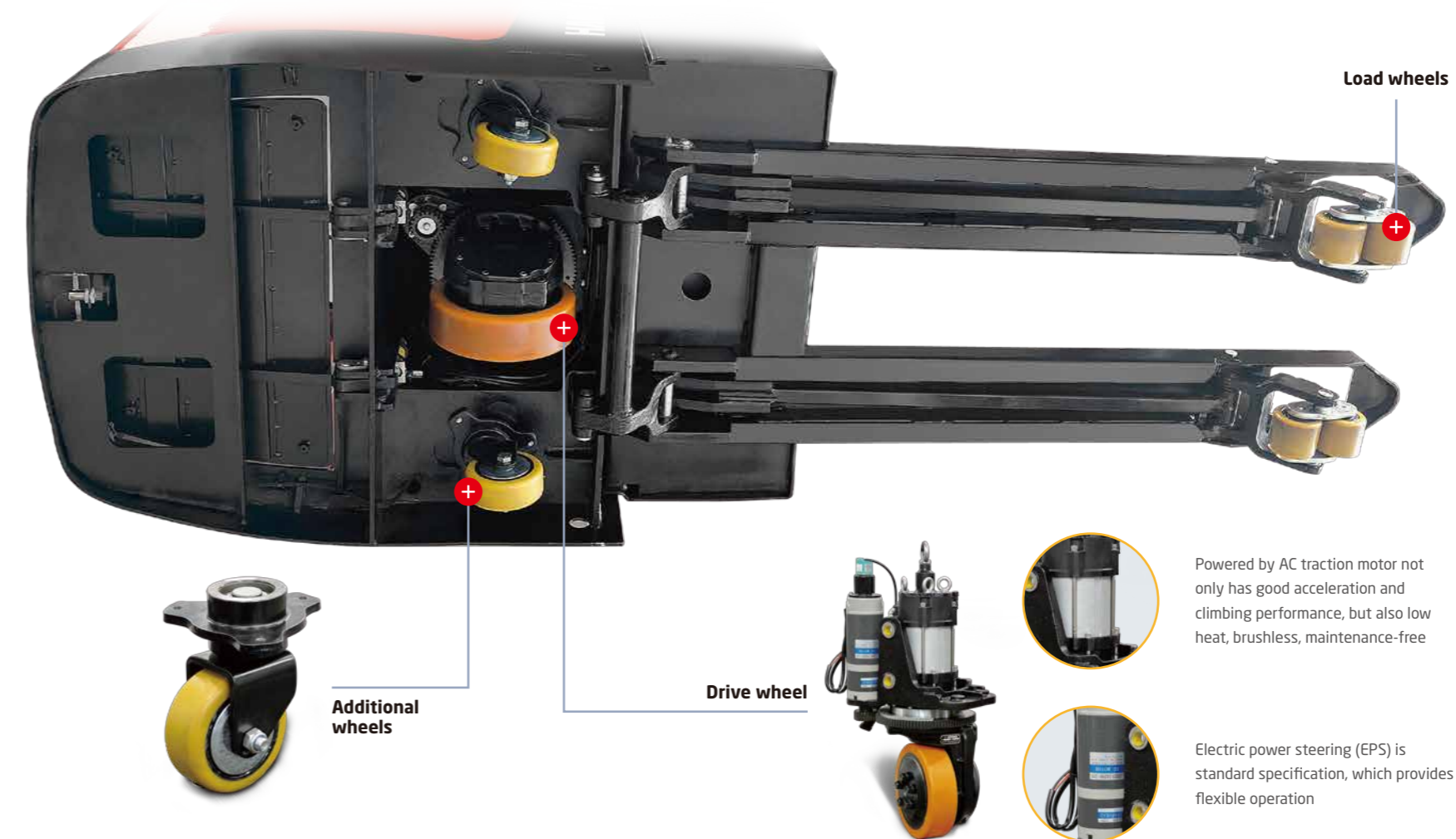

Comfort

- / Smooth driving and more comfortable operating experience thanks to a new design of the floating drive suspension system.
- / The compact body and semicircular design provide an ideal operation in limited space, and the wedge designed chassis greatly increases the passing ability.

Maintenance

- / AC motor without carbon brushes, maintenance-free, cost saving.
- / Integrated battery indicator, hour meter and self-diagnostic instrument.
- / Full opened hood, easy accessibility of all components, is easy for service.
- / All shafts installed lubricated shaft sleeve and oil cup, provide convenient maintenance and long service life.

Standard specification

- / AC drive motor
- / AC controller
- / Electric Power Steering (EPS)
- / Emergency switch
- / 1150mm fork length
- / Side battery change
- / Multi-function battery indicator
- / CAN-bus technology
- / 540mm outside fork width
- / Automatic speed reduction when cornering
- / Imported hydraulic unit
- / Brake switch

Options

- / Different length of fork
- / Different capacity of battery



The pedal applies shock absorption design, greatly improve the operator's comfort, reduce the fatigue



Optimized designing structure to offer a good visibility and easy entrance of the pallet



Side battery change is standard feature



Simple and beautiful tiller designed to make the operator feel comfortable, all the operation can be completed by one hand