



Electric Stacker With Initial Lift

with capacities of 800 to 1,200kg

Application

/ Carrying two pallets at a time, improve working efficiency; extraordinary traction in crossing door and dock.

Operator Controls

/ With the new design of ergonomic tiller head, all buttons can be reached conveniently & comfortably.

Electrical And Drive Unit

/ World-class hydraulic power pack, with low noise, few vibration and excellent leak tightness, automatically adjusts the rate of decline whether loaded or unloaded, and ensures smooth lifting. The innovative AC system offers quick response, accurate control, impact structure, excellent performance, longer battery working life. American AMP connectors with top quality, prevents moisture and contaminants from interrupting truck operation in all environments, plus all the wires and cables reliably protected and fixed, greatly reduces the electrical error.

Regenerative Brakes

/ The latest AC controller, high reliability, with regenerated braking, anti-roll back and adjustable settings, ensures the best performance in the different states. Anti-roll back available as standard to prevent uncontrolled traveled travel speed or roll-back on ramps when loading and unloading.



Reliability

/ Explosion-proof valve installed under lifting cylinder, prevent the mast go down quickly if the oil pipe broken. H shape mast improves the strength of the whole truck. Easy-Touch emergency plug mounted at up-right side on truck frame help operator take immediate action for any emergent happens. The truck switches to low speed mode automatically when lifting higher than 0.5m, more secure.
/ Sideway battery design of 1.2t for easy battery replacement.

Options

/ Different fork length / High battery capacity for different model

CDD10-W-D

		Lift Height(mm/in)	Capacity(kg/lb)
	Support Arm	210/8.3	1800/3968
	Mast Fork	1600/63	1000/2205
	Mast Fork	3000/118	800/1764
	Support Arm	210/8.3	1000/2205
	Mast Fork	1600/63	800/1764

CDD12-W-D

		Lift Height(mm/in)	Capacity(kg/lb)
	Support Arm	210/8.3	2000/4409
	Mast Fork	1600/63	1200/2646
	Mast Fork	3000/118	1000/2205
	Support Arm	210/8.3	1000/2205
	Mast Fork	1600/63	1000/2205

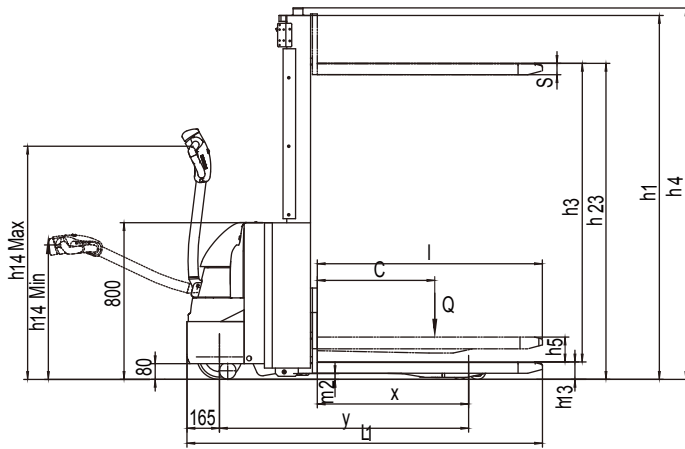

CDD08-W-D
Dimensions

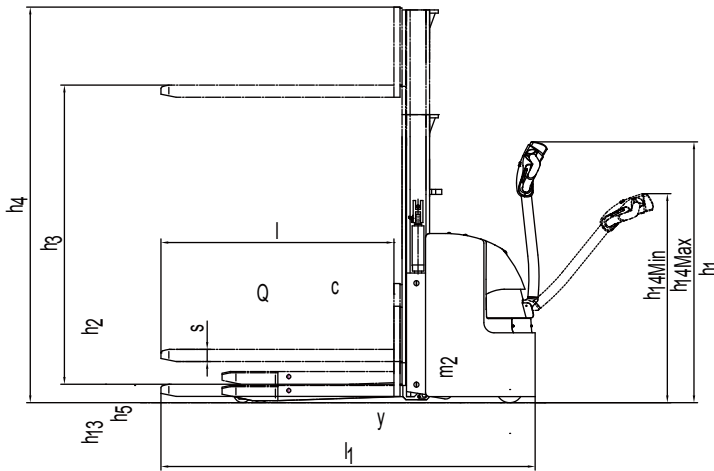
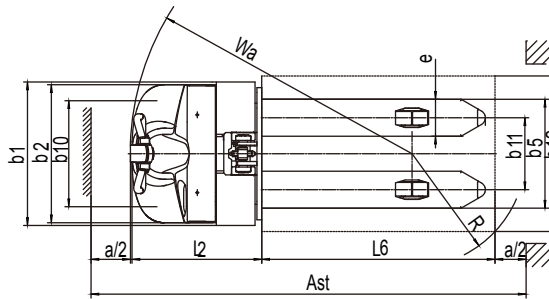

CDD10(12)-W-D
Dimensions

