



ZHEJIANG HANGCHA IMP. & EXP. CO., LTD.

Factory site: 666 Xiangfu Road,
Hangzhou, Zhejiang, China (311305)

Tel: +86-571-88926735 88926755
Fax: +86-571-88926789 88132890

sales@hcforklift.com
www.hcforklift.com



Follow us on
Facebook



Follow us on
YouTube



Follow us on
WeChat



ISO14001
ISO14001:2015



ISO9001
ISO9001:2015



HANGCHA trucks conform
to the European Safety
Requirements.

2018 VERSION 1 / COPYRIGHT 2018/05

HANGCHA GROUP CO., LTD. reserves the right to make any changes without notice concerning colors, equipment, or specifications detailed in this brochure, or to discontinue individual models. The colors of trucks, delivered may differ slightly from those in brochures.



J Series Electric Forklift Truck

with capacities of 8,000 to 10,000kg

[8000kg @900mm , 9000/10000kg @600mm]

The World of Hangcha



Appearance

/ Body choosing modern large circular arc streamline surface modeling, is in accordance with international design trend.

Comfortable

/ Soft landing system is applied for it, when the fork lows to 100-500mm to ground, the soft landing system is auto operated, it can avoid the forks dashing against the ground.

/ New dashboard is easy to see and provides friendly human-computer interaction with multiple functions.

/ Low noise, energy saving and no exhaust emission, all meet the environment friendly requirement.

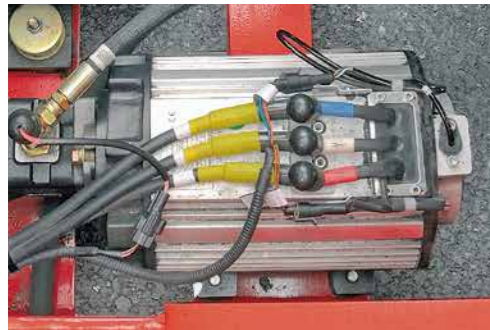

/ Steering braking and lifting hydraulic adopts two independent hydraulic system, to ensure the braking performance, realize the joint operations.



/ The front-rear type designed battery layout technology provides excellent stability.



/ Ergonomically designed adjustable angle of steering wheel, and 150mm adjustable distance of seat, both provide better operator's comfort of different operators.



/ International advanced Full-AC controller can control the travelling, lifting, braking and turning action. It provides stable and accurate control, speed control performance is superior, regenerative braking, reverse connect braking, anti-slope and other functions, make the operation more efficient, safe and comfortable.

Front dual tyre



Standard specification

- / Full-AC motor & controller
- / Multi-function dashboard
- / Full electric controlled travelling, lifting, steering and braking
- / Front light system, turning indicator, combined rear light
- / Standard battery
- / Emergency switch
- / Reversing beeper
- / Full hydraulic steering and braking
- / Suspension seat
- / Soft landing system
- / 3m duplex wide view mast
- / Standard forks
- / Super elastic solid tyre
- / Left and right rear view mirror
- / Toolbox
- / Pin

Options

- / Big capacity import battery
- / Charger
- / Rear working light
- / Colored solid tyre
- / Duplex mast with full free lift
- / Triplex mast with full free lift
- / Other length fork
- / Wider or higher load backrest
- / Attachments

Battery

Capacity(Ah/5h)	8t	9t	10t
900	○		
960	●	○	
1104	○	●	○
1260	○	○	●

Note: ● STD. ○ OPT.



Small dimension solid tyre



You can open the door on each side, it make the motor, oil pump and electrical controller maintenance is very convenient, provide good waterproof and dustproof



New designed broad view mast provides better forward view ability



Full opened battery cover is easy for battery service

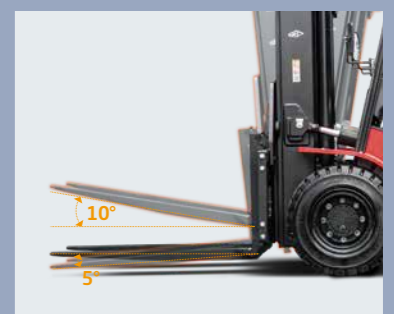



Easy/ Efficiency/ Economy



Advanced

- / Big LCD dashboard is easy to see and provides friendly human-computer interaction and with running hours, self-diagnosis function and mode selection.
- / Regenerative brake(When parking, reversing and declining, the drive motor will charge the battery, energy saving).
- / Energy saving LED lamp.

Reliability & Safety

- / Motor controller, contactor, power plug, emergency switch, instrument and other major electrical components adopt international brand products.
- / Electronic and hydraulic overload protection device.
- / CE Certification.

AC Advantages

- / Three motors are all Full-AC, free maintenance, low cost.
- / High efficiency AC system with full protection functions provides reliability and long working life.